

VERZUS 750CCD

Universal Hardness Tester





VERZUS 750CCD
1 KGF/9.8N TO 250KGF/2.45KN, BUILT-ON CAMERA

The VERZUS 750 series are a new generation of hardness testing instruments. The testers are constructed around a rock solid C-frame with unparalleled rigidity. The closed loop system based on a load cell and precision force actuator guarantees the best GR & R results ever seen on Rockwell hardness testers. The tester meets or exceeds the ISO, ASTM and JIS standards and conforms to Nadcap auditing.

Test forces range from 1kgf/9.8N to 250kgf/2.45kN, Advanced algorithms, digital filter technology and state of the art electronics provide unmatched force control. The test cycle can be as little as 13 seconds (at a dwell time of 10 seconds).

Depth measurement via an optical system with a direct reading of **0.1 micron**.

VERZUS stands for versatile. The 750CCD is equipped with Rockwell, Superficial Rockwell, Vickers, Brinell, HVT, HBT and Depth ball measurement. All models also include Plastic testing scales according to ISO 2039/1.

The VERZUS **750CCD** offers more ...

An embedded powerful PC runs the hardness testing software IMPRESSIONS™. This allows you to mount the optional Y-axis motorized Jominy stage or coordinate testing table (X-Y stage) for pattern testing. Also suitable for Eht. A CCD camera system with LED ring light recording all Brinell and Vickers indentations and measuring the results automatically. At a finger touch you store all results on the systems hard disk database. Automatic measurement, indent ZOOM function, conversions to other scales, other standards and many additional functions are part of the standard delivery.

At your convenience the VERZUS 750 models can be equipped with a motorized spindle that lifts your work piece, without any effort, to the required testing or measuring position. Ideal for smaller workshops, educational purposes and for those who want to be versatile in hardness measurement with a larger scale of automation.

The outer skin of the tester is made of recyclable top class materials. The base is covered by a ABS shell that can withstand the harshest environments. No damage from falling testblocks or workpieces.

VERZUS if being certain is your priority!

FEATURES

- Load cell, force feedback, closed loop system
- Unparalleled rigidity
- Unmatched GR & R results
- Load range 1kgf/9.8N up to 250kgf/2.45kN
- Fully automatic operation
- Rockwell, Superficial Rockwell, Vickers, Brinell, HVT, HBT, Ball indentation for plastic ISO 2039/1
- Meets or exceeds ISO, ASTM and JIS standards
- Shape correction settings for curved surfaces
- Optical depth measuring system (Rockwell, HBT, HVT, Ball indentation for plastic ISO 2039/1)
- Powerful Embedded PC with 2 hard disks and HD industrial touch screen
- IMPRESSIONS™ high end video based hardness testing firmware including CCD camera, automatic indent measurement, indent ZOOM system, conversion to other hardness scales, test data & image storage, statistic results storage, Jominy stage operation, X-Y stage operation.
- Password and user level access system
- Easy calibration function
- Standard workpiece clamping attachment
- Workpiece sliding table
- Large work piece accommodation
- Motorized spindle (Optional)

TECHNICAL SPECIFICATIONS

Hardness scales	Rockwell, Superficial Rockwell, Brinell, Vickers, HVT, HBT and Ball indentation for plastic ISO 2039/1
Load application	Load cell, force feedback, closed loop system
Load range	1kgf/9.8N to 250kgf/2.45kN
Test loads	1kgf/9.8N, 2kgf/19.6N, 2.5kgf/24.5N, 3kgf/29.4N, 4kgf/39.2N, 5kgf/49N, 6.25kgf/61.29N, 10kgf/98N, 15kgf/147N, 15.625kgf/153.2N, 20kgf/196.13N, 25kgf/245.16N, 30kgf/294.19N, 31.25kgf/306.45N, 45kgf/411.29N, 50kgf/490N, 60kgf/588.4N, 62.5kgf/612N, 100kgf/980.7N, 120kgf/ 1176.79N, 125kgf/1225N, 150kgf/1471N, 187.5kgf/1838N, 250kgf/2.45kN
Vickers test range	HV: 1kgf/9.8N, 2kgf/19.6N, 3kgf/29.4N, 4kgf/39.2N, 5kgf/49N, 10kgf/98N, 20kgf/196.13N, 30kgf/294.19N, 50kgf/490N, 100kgf/980.7N, 120kgf/ 1176.79N HVT: 50kgf/490N, 100kgf/980.7N
Brinell test range	HB1: 1kgf/9.8N, 2.5kgf/24.5N, 5kgf/49N, 10kgf/98N, 30kgf/294.19N HB2.5: 6.25kgf/61.29N, 15.625kgf/153.2N, 31.25kgf/306.45N, 62.5kgf/612N, 187.5kgf/1838N HB5: 25kgf/245.16N, 62.5kgf/612N, 125kgf/1225N, 250kgf/2.45kN HB10: 100kgf/980.7N, 250kgf/2.45kN HBT2.5: 62.5kgf/612N, 187.5kgf/1838N HBT: 5kgf/49N, 250kgf/2.45kN
Rockwell test scales	A, B, C, D, E, F, G, H, K, L, M, P, R, S, V 15N, 30N, 45N, 15T, 30T, 45T, 15W, 30W, 45W, 15X, 30X, 45X, 15Y, 30Y, 45Y
Plastic Ball indentation	According to ISO 2039/1
Optical system	High resolution video camera mounted on build on microscope
Objectives	Interchangeable 2.5x, 5x and 10x magnification, with LED ring light (optional)
Eyepiece	10x magnification (15x optional)
Scale resolution (depth)	0.1 micron
Display	Large high definition industrial 8.4" touch screen can also be operated by mouse and keyboard
Service connection	Firmware service over internet "INNOVATEST team viewer" pre-installed
Standards	Meets or exceeds, ISO, ASTM, JIS (Nadcap) standards
Test cycles	Fully automatic, Load, Dwell, Unload
Indentors (optional)	Rockwell Diamond Cone: 120° Rockwell balls: 1/16", 1/8", 1/4", 1/2" Vickers Diamond: 136° Brinell/Balls: 1mm, 2.5mm, 5mm, 10mm Some are optional
Dwell time	1 - 99 seconds
Connectivity	USB-2 (6) RJ-45 LAN, W-LAN, (RS-232)
Workpiece accommodation	Vertical capacity 300mm (260mm with sliding table), Horizontal capacity 200mm (from center-line)
Operating temperature	10°C to 35°C, non-condensing
Machine dimensions	290mm x 588mm x 895mm (WxDxH)
Machine weight	109kg
Power supply	100V AC to 240V AC, 50Hz/60Hz, single phase

STANDARD DELIVERY

- Flat anvil, hardened, $\varnothing 60\text{mm}$
- V-anvil, hardened, $\varnothing 80\text{mm}$
- Sliding testing table
- Build on microscope with HD CCD camera
- Objectives 2.5x, 5x and 10x
- Fuse 3A slow (2 pcs)
- Power cable
- Four adjustable feet
- INNOVATEST® certificate
- Installation and user manual

OPTIONAL ACCESSORIES

- Factory indentors
- Certified indentors (UKAS, DKD, ASTM)
- Factory reference hardness blocks
- Certified reference hardness blocks (UKAS, DKD, ASTM)
- Testing table, hardened, $\varnothing 180\text{mm}$
- Large testing table 350mm x 250mm with T-slot and spindle adapter
- Custom testing tables
- Goose neck indenter holder
- Precision vice for small parts, jaw width 36mm
- Precision vice for small parts, jaw width 42mm
- Precision vice for small parts, jaw width 75mm
- V-blocks and special clamps
- Manual X-Y stage 100mm x 60mm, micrometer travel 25mm x 25mm
- Motorized Y-stage for jominy testing
- Motorized X-Y stage for pattern testing
- Motorized spindle operation
- LED ring light for dark field illumination
- Knoop hardness testing scale
- Solid tester table and storage cabinet
- 700STARTKIT/1:
Testing table, hardened, $\varnothing 180\text{mm}$
set of factory reference hardness test blocks,
set of factory indentors



Round test table



Motorized stage



Extra large working table

ORDER DETAILS

VERZUS 750 CCD

Rockwell, Superficial Rockwell, Brinell, Vickers, HVT, HBT,
Ball indentation for plastic ISO 2039/1,
test forces 1kgf/9.8N to 250kgf/2.45kN

TECHNICAL DRAWING

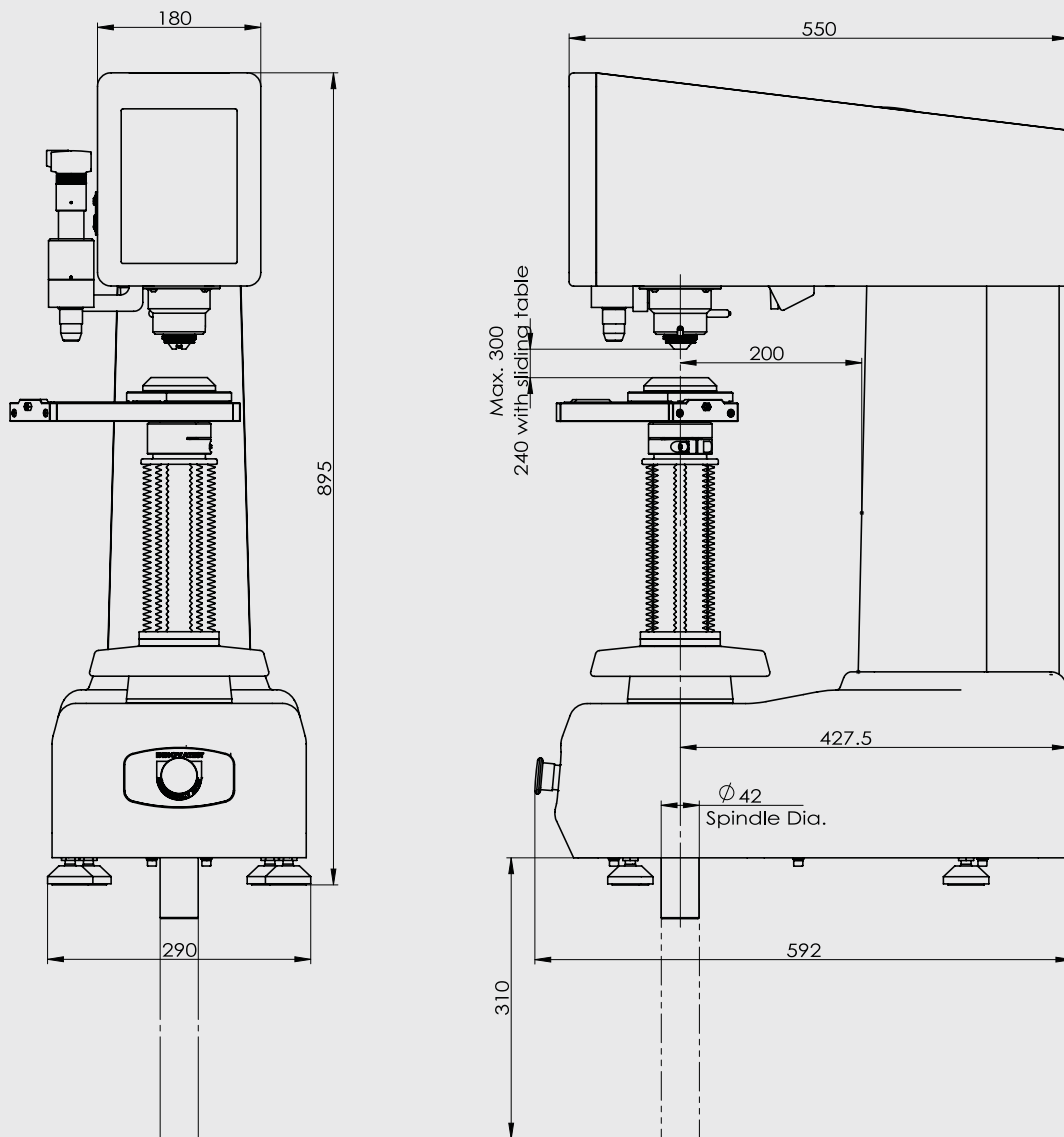

All dimensions are in mm

TECHNICAL DRAWING

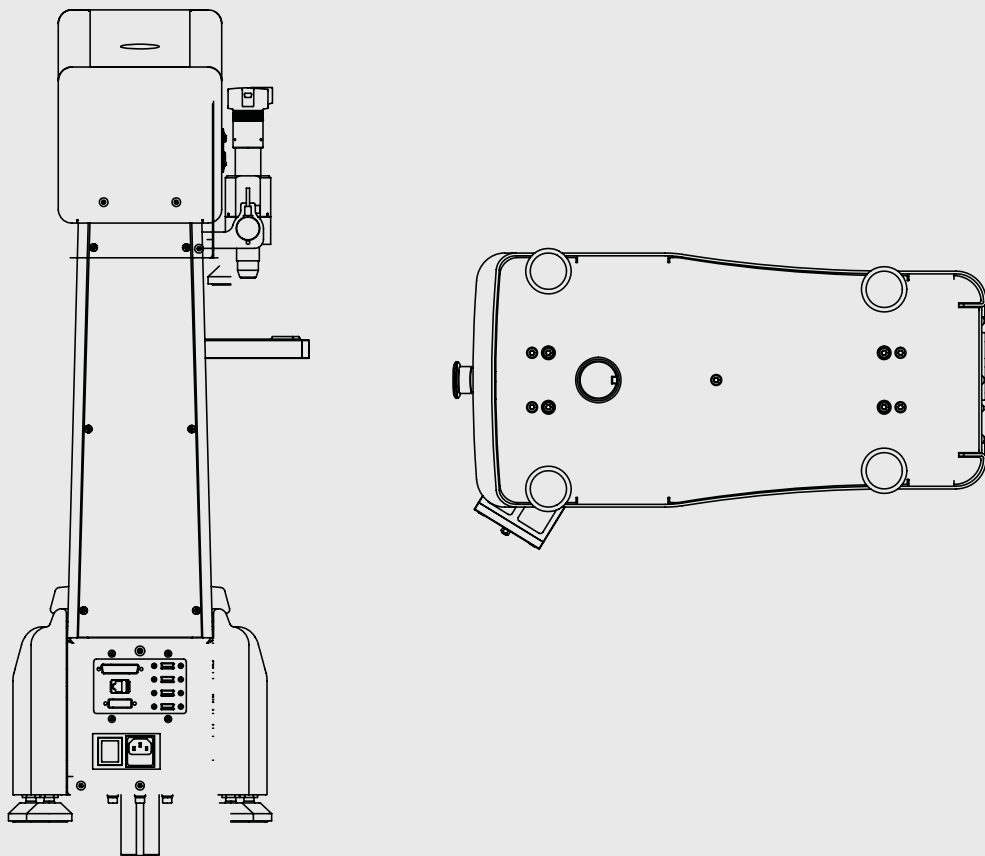

All dimensions are in mm

Represented by:

INT2-153 040214

CORPORATE HEAD OFFICE

MANUFACTURING, DISTRIBUTION & SERVICE

INNOVATEST Europe BV

Borgharenweg 140
6222 AA Maastricht (The Netherlands)
Phone: +31 43 3520060
Fax: +31 43 3631168
Email: info@innovatest-europe.com

INNOVATEST Benelux BVBA

SALES & SERVICE

Phone: +32 12 779002
Fax: +32 12 779003
E - mail: info@innovatest - benelux.com

INNOVATEST Shanghai Co., Ltd.

DISTRIBUTION, SALES & SERVICE

Building 2, No.123, 1165 Nong Jindu Road,
South Metropolis Industrial Park,
Minhang District, Shanghai, P.R. China
Zip code: 201108
Phone: +86 21 60906200
Fax: +86 21 60912595
E - mail: info@innovatest - shanghai.com

Changes in products and/or product specifications can emerge due to new technologies and continuous development. We reserve the right to change or modify specifications of products without prior notice. We recommend you to contact our sales office for up-to-date information.

© All rights reserved

www.innovatest-europe.com